



INSTALLATION INSTRUCTIONS

Accessory	Application	Publications No.
ENGINE BLOCK HEATER P/N 08T44-SNA-101	2015 TLX L4	VERSION 1
		Issue Date JULY 2014

PARTS LIST

Engine block heater



Aluminum washer



Heater harness

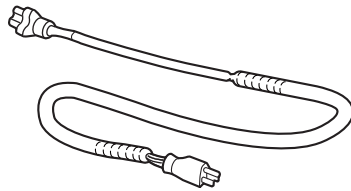

Protective cap



12 Black wire ties
(7 Not used)



7 Wire ties with clip
(6 Not used)



5 Beige wire ties
(4 Not used)



TOOLS AND SUPPLIES REQUIRED

Phillips screwdriver

Ratchet

10 mm, 19 mm, and 24 mm Sockets

10 mm Open end wrench

Torque wrench

Diagonal cutters

Heavy gloves

Drain pan

Tape measure

White marker

Coolant (Acura Long Life Antifreeze/Coolant Type 2)

Blanket

Fender cover

Masking tape

Hacksaw

File

The following tool is available through the Honda Tool and Equipment Program. On the iN, click on: Service > Service Bay > Tool and Equipment Program, then enter the number under "Search". Or, call 888-424-6857.

- Trim Tool Set (T/N SOJATP2014)

Illustration of the Engine Block Heater Installed on the Vehicle

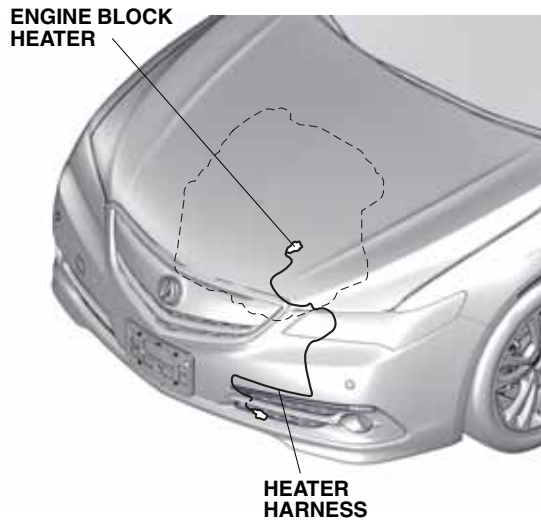

INSTALLATION

Client Information: The information in this installation instruction is intended for use only by skilled technicians who have the proper tools, equipment, and training to correctly and safely add equipment to your vehicle. These procedures should not be attempted by “do-it-yourselfers.”

NOTE:

- Always use Acura Long Life Antifreeze/Coolant Type 2. Using a non-Acura coolant can result in corrosion, causing the cooling system to malfunction or fail.
 - To avoid burning out the element, do not operate the engine block heater until it is installed in the vehicle and you have added coolant.
1. Disconnect the negative cable from the battery.
 2. Allow the engine and all cooling system components to cool down.

3. Place a clean drain pan under the radiator drain plug, then remove the drain plug from the bottom of the radiator to drain the coolant. Remove the radiator cap to increase the flow.

NOTICE: Radiator coolant will damage the paint. Quickly rinse any spilled coolant from the paint.

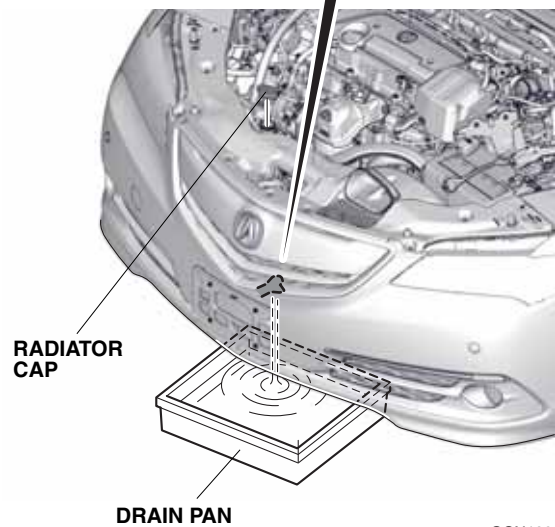
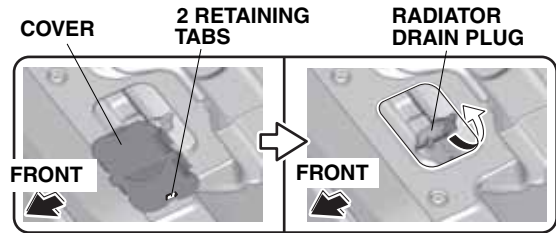

4. Drain the coolant completely, then reinstall the radiator cap.

- Attach masking tape to the front bumper, headlights and front fenders as shown.

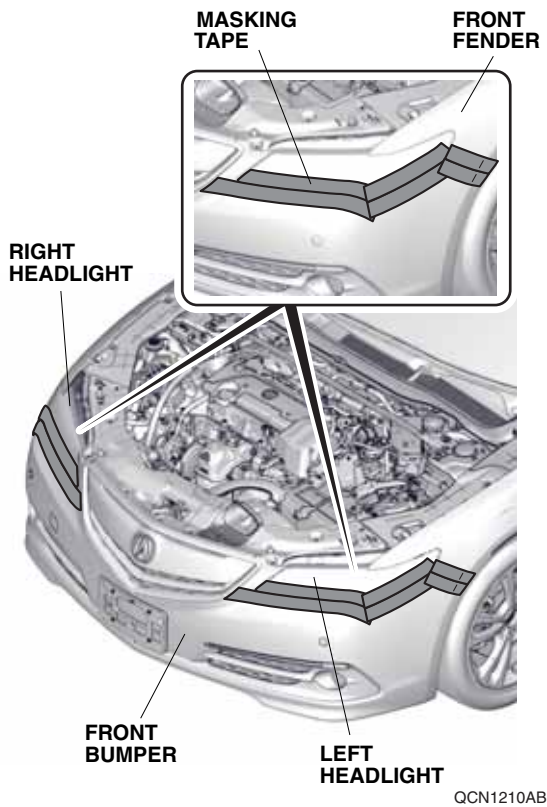

- Remove the intake air tube.

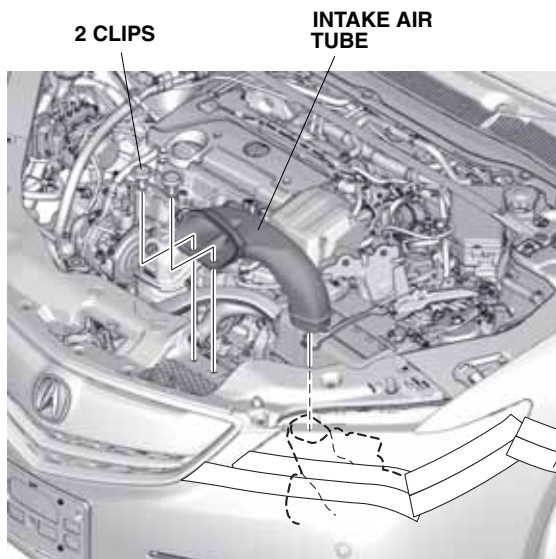

- Remove the front grille cover.

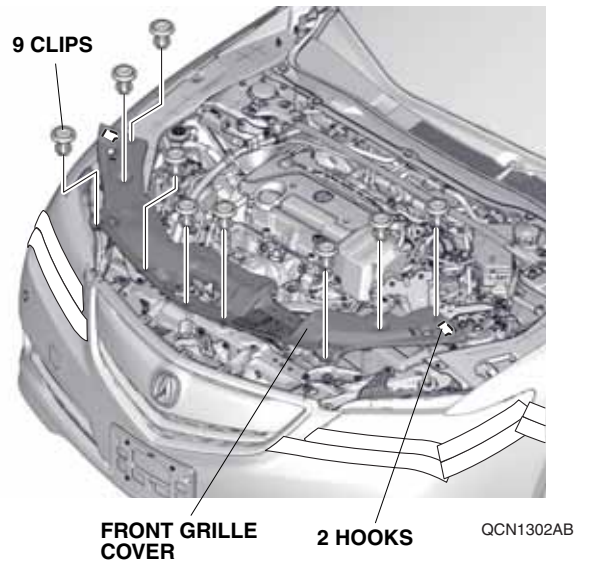

- Remove the front grille.

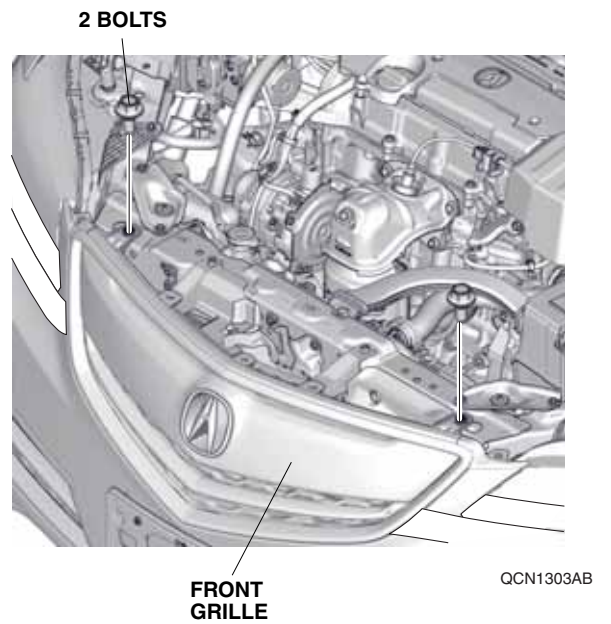

9. Remove the left strake from the front bumper and air dam.

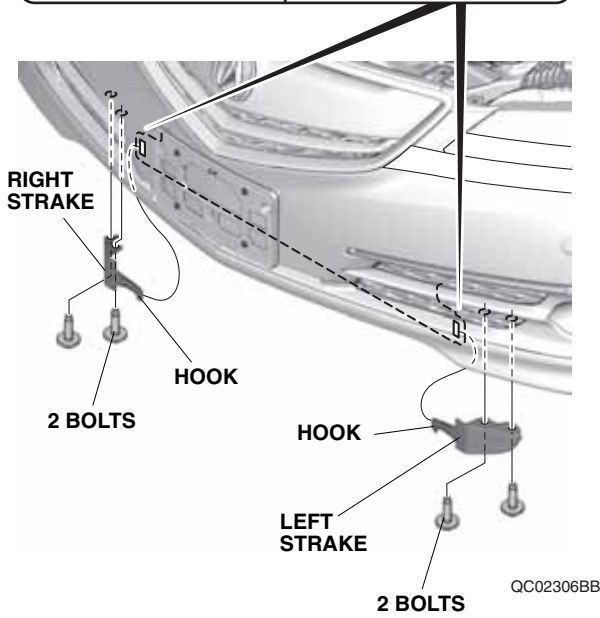
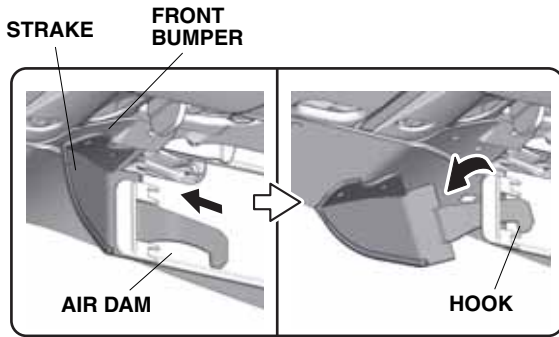

10. Repeat step 9 to remove the right strake.

11. Remove the front bumper.

- Remove the two self-tapping screws, eight clips, and six bolts.

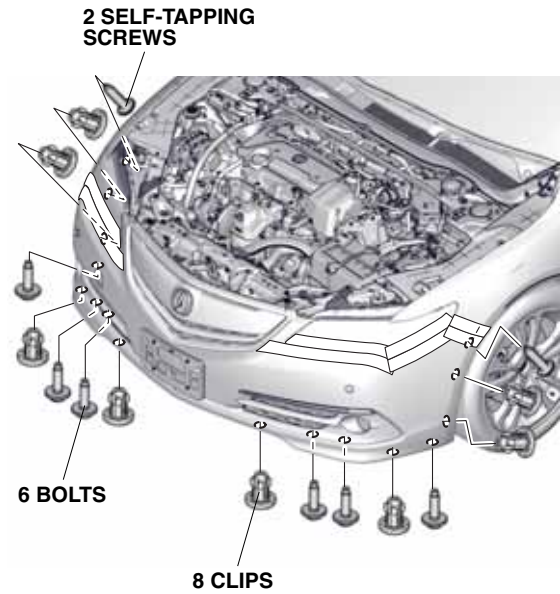

- Release the five retaining tabs on each side.

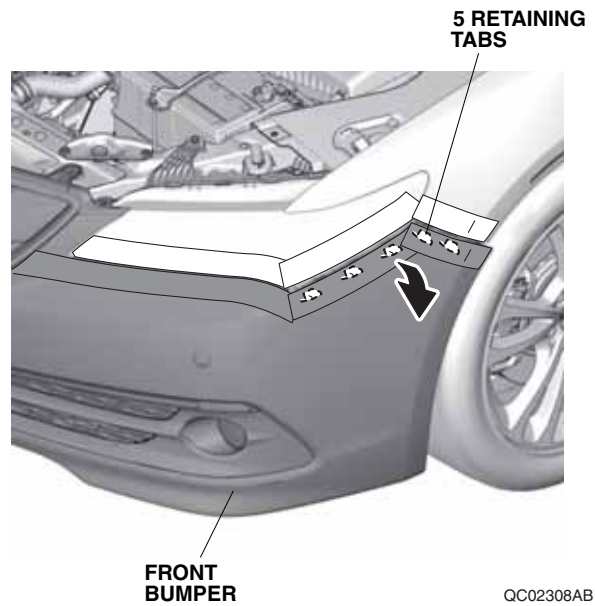

- Release the five retaining tabs on each side.

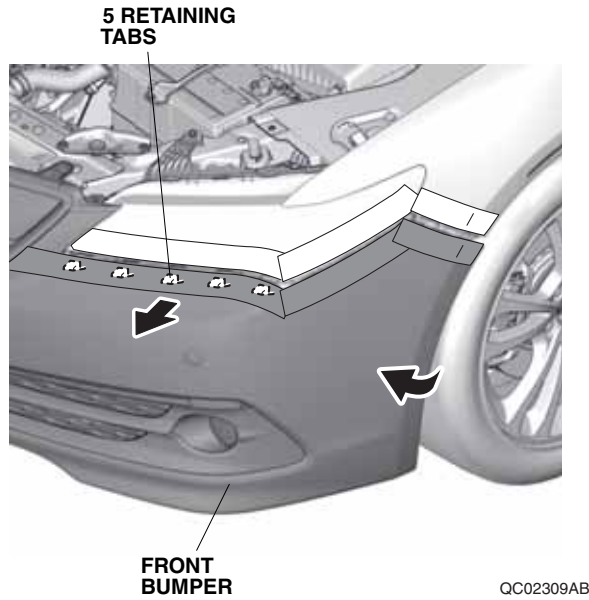

- With the help of an assistant, remove the front bumper.
- Unplug the vehicle connectors and remove the clip.
- Place the front bumper on a blanket.

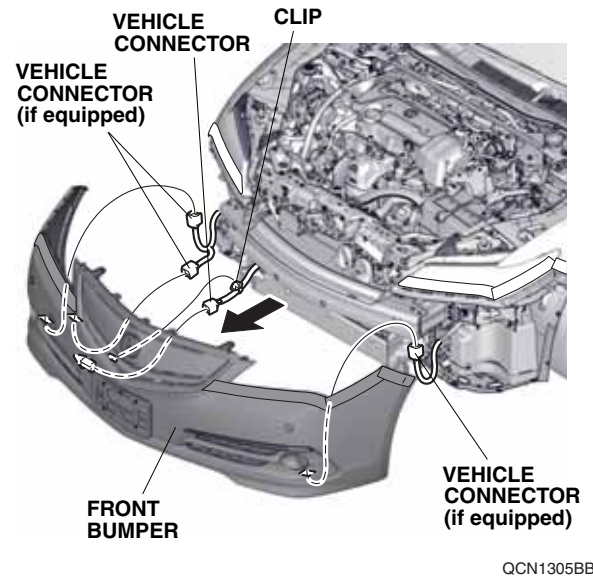

- Using a tape measure and a white marker, mark the heater harness at the measurements **A**, **B**, **C**, **D**, and **E**.

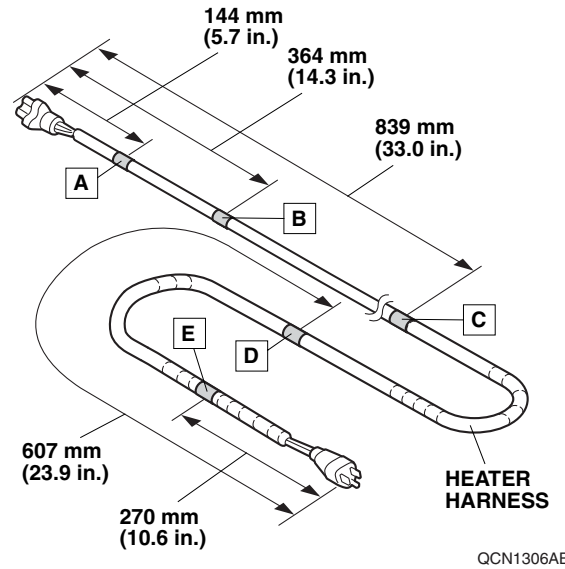

- Install one wire tie with clip to the heater harness at point **A**.

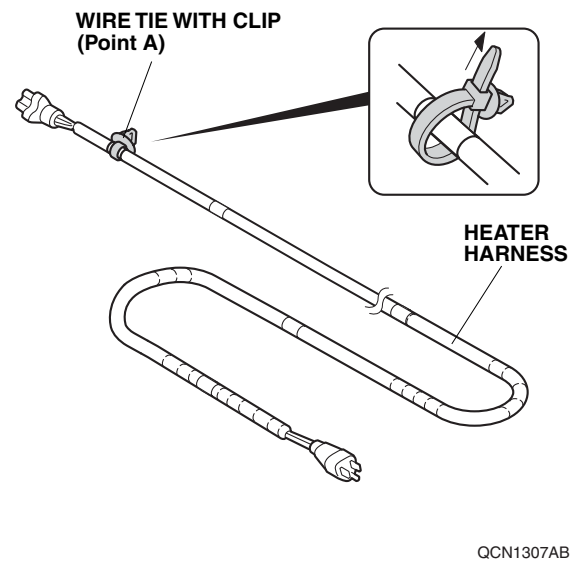

14. Locate and remove the drain bolt and washer. Coolant remaining in the engine jackets flows out of the hole when the drain bolt is removed. Retain the drain bolt in case the engine block heater is removed.
NOTE: Use a new washer if the drain bolt is reinstalled.

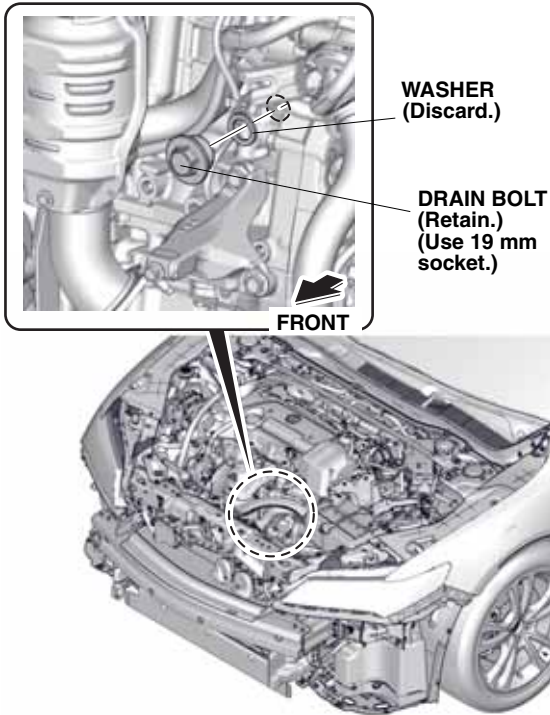

QCN1308AB

15. Install the engine block heater with the aluminum washer into the bolt hole using a 24 mm socket. Torque the engine block heater to 80 N-m (8.2 kgf-m, 59 lbf-ft).

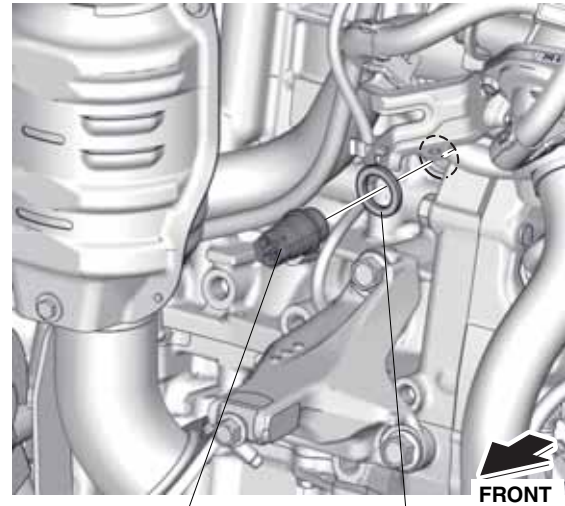

QCN1309AB

16. Plug the heater harness connector into the engine block heater. Make sure the heater harness connector is fully seated in the engine block heater.

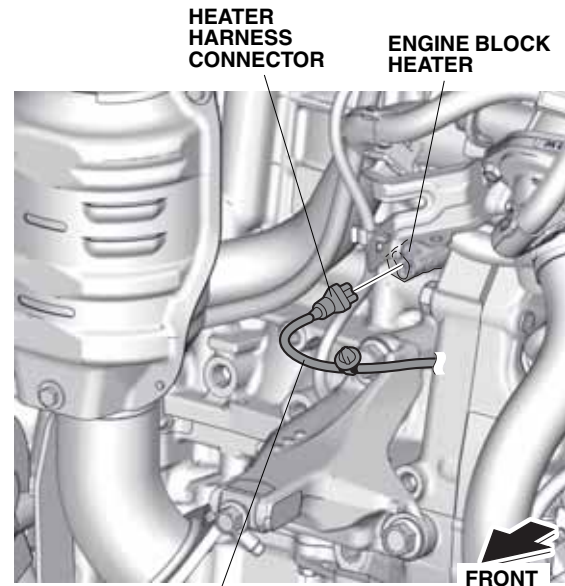

QCN1310AB

17. Route the heater harness in the direction shown, and secure the heater harness to the vehicle bracket with one wire tie with clip installed in step 13.

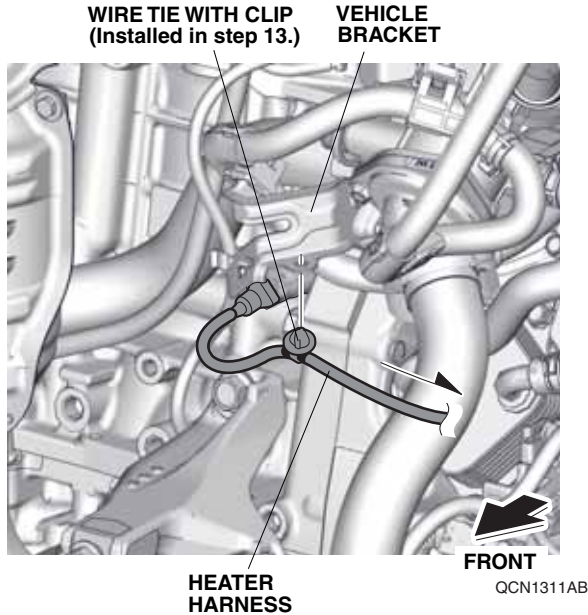

18. Route the heater harness toward the fan shroud, and secure the heater harness to the fan shroud rib with one beige wire tie at point B.

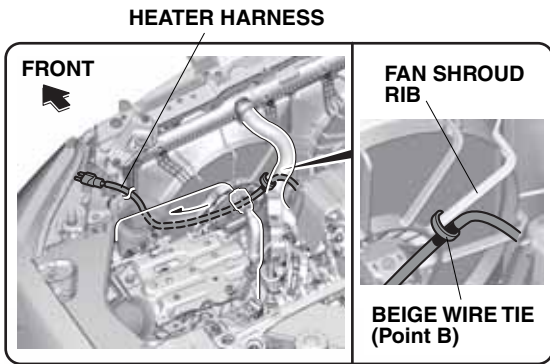

QCEN1312AB

19. Route the heater harness down behind the front bumper beam, and secure the heater harness to the vehicle harness with one black wire tie at point C.

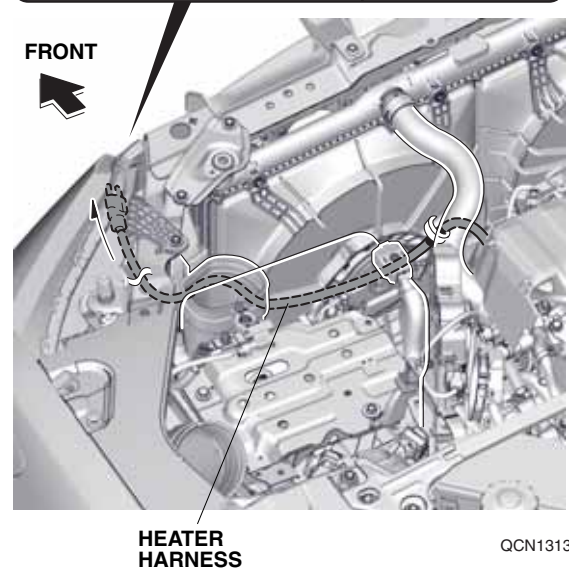
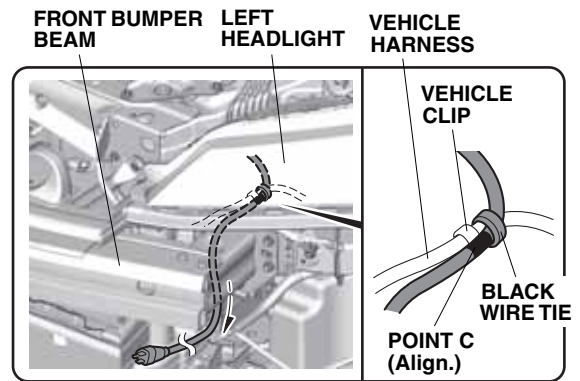

20. Secure the heater harness to the fan shroud rib with two black wire ties.

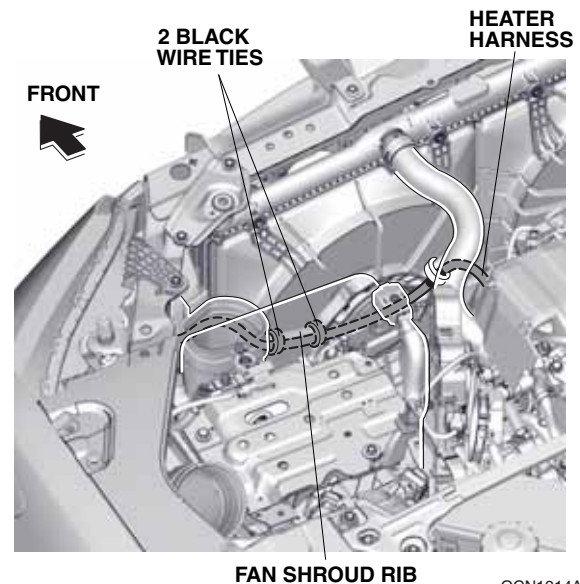

21. Bundle up the excess heater harness, and secure it to the vehicle harness with one black wire tie at point **D**.

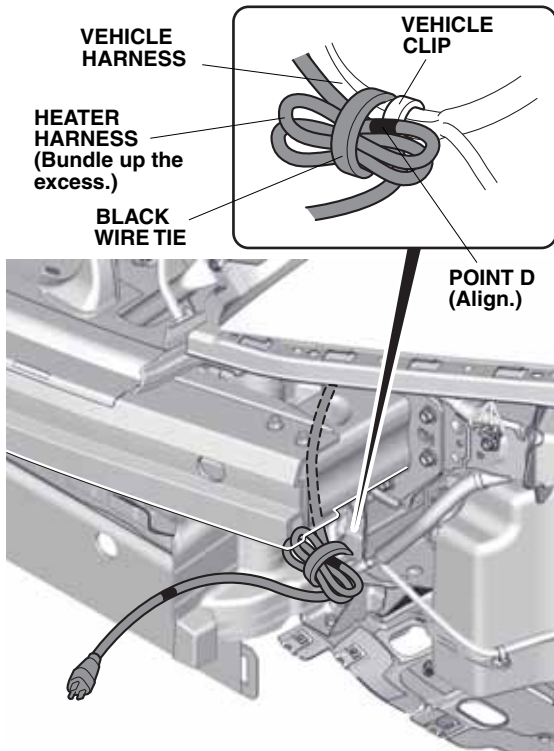

QCN1202AB

22. Using a hacksaw, cut the left lower grill as shown. Remove any burrs.

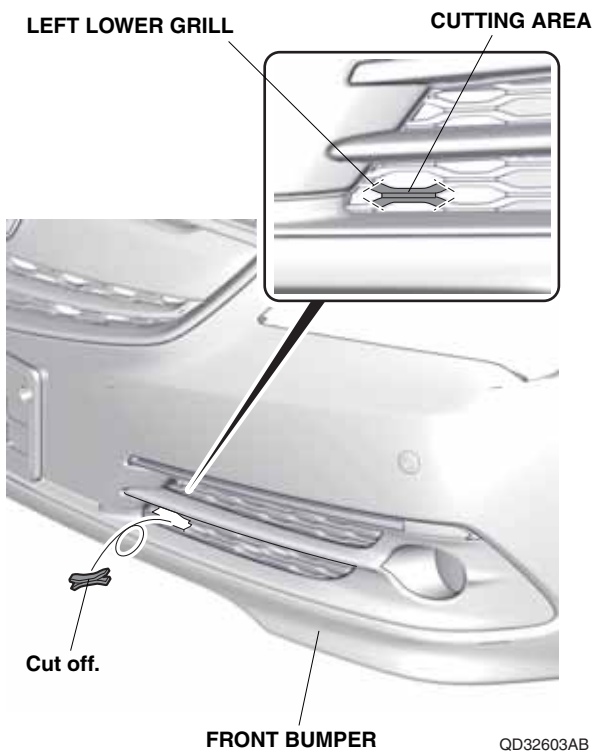

QD32603AB

23. Attach the protective cap to the left lower grill.

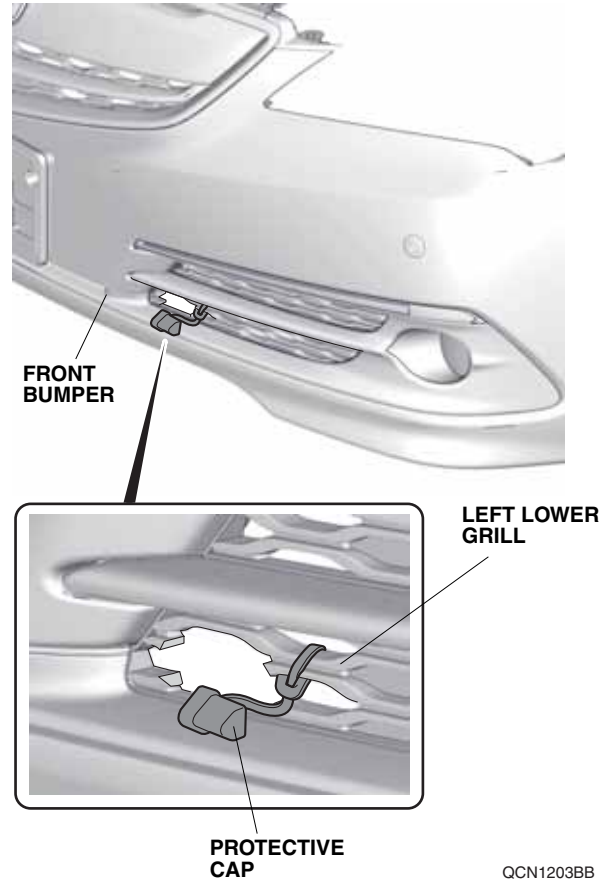

QCN1203BB

24. Route the heater harness through the slit as shown.

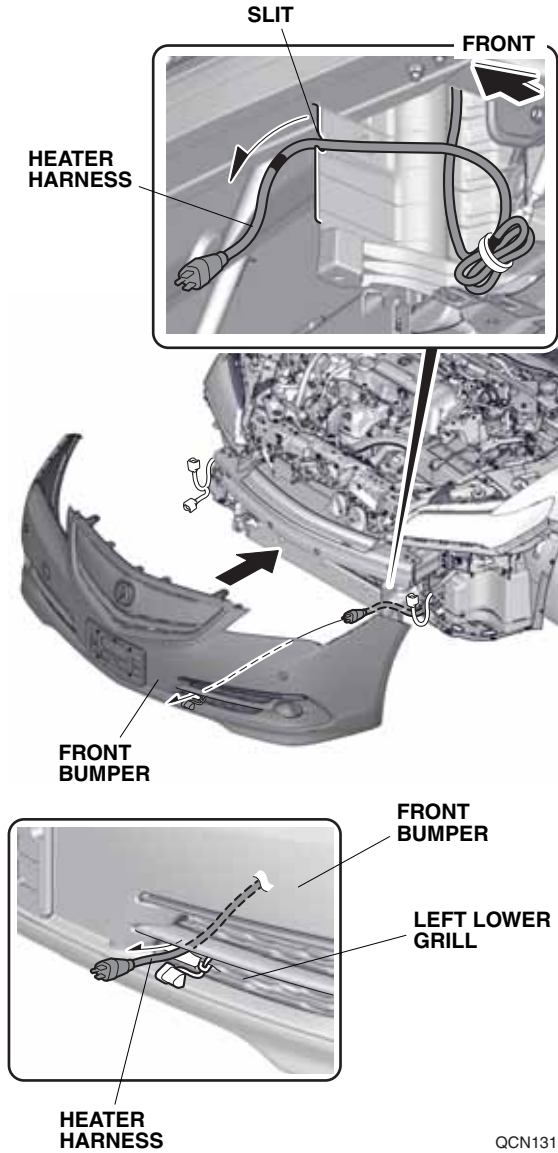

25. With the help of an assistant, bring the front bumper close to the vehicle. Route the heater harness through the cutoff in the left lower grill as shown, then reinstall the front bumper.

If the vehicle is equipped with front parking sensors, continue with step 26; otherwise, go to step 27.

Vehicles With Front Parking Sensors

26. Secure the heater harness to the front parking sensor harness with one black wire tie at point E as shown. Go to step 28.

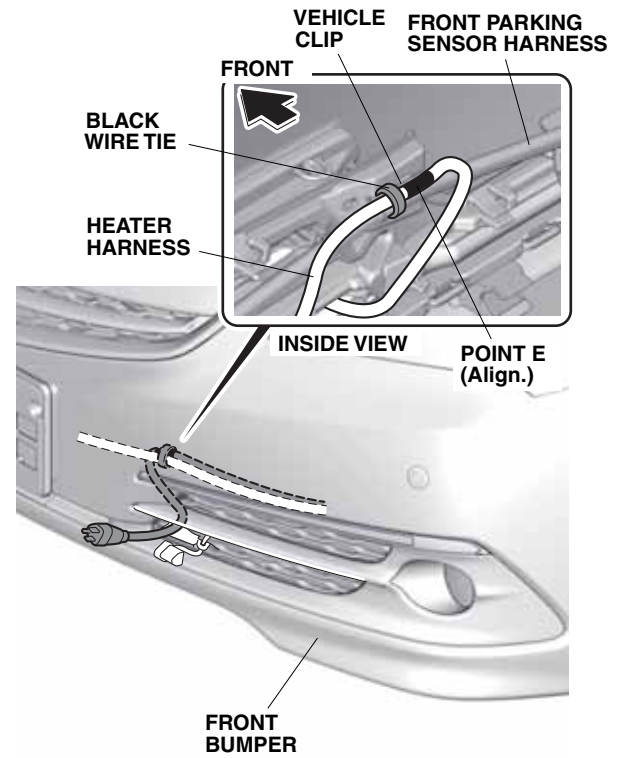

QC�1206BB

Vehicles Without Front Parking Sensors

27. Secure the heater harness to the left lower grill with one black wire tie at point **E**.

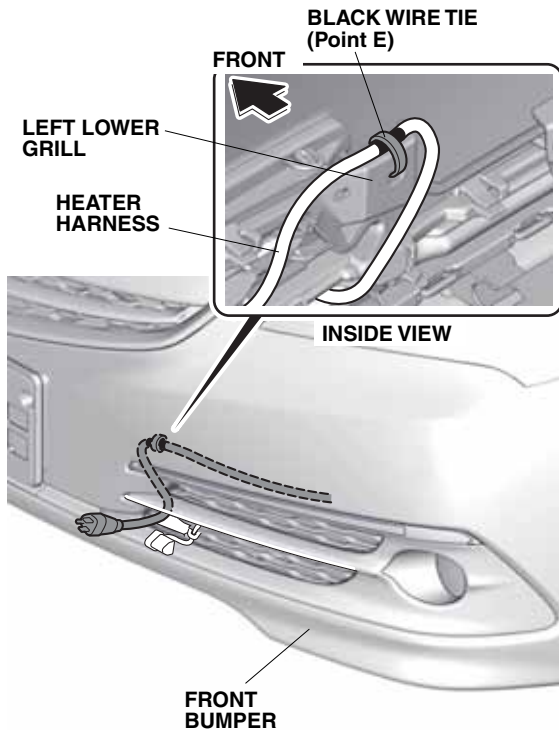

QCN1205BB

28. Plug the heater harness connector into the protective cap.

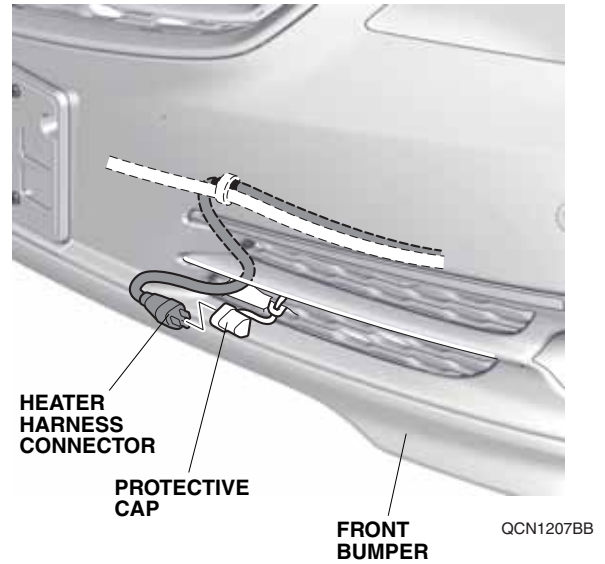

29. Reinstall all removed parts except for the front grille cover and the intake air tube. Make sure the heater harness sits in the slit as shown in step 24.
30. Reinstall the radiator drain plug.
31. Remove the radiator cap and fill the system with the recommended coolant. Follow the instructions in the Service Manual to fill the cooling system and check for leaks. In particular make sure that there is no leak around the engine block heater.
32. Make sure that the heater harness is routed properly and all connectors are plugged in.
33. Reinstall the radiator cap.
34. Put the drain bolt (removed in step 14) in the glove box.
35. Reconnect the negative cable to the battery.
36. Reinstall the front grille cover and the intake air tube.
37. Press and hold the radio power button for two seconds to restore radio and navi (if equipped) system functions.
38. Reset the clock.
39. Restore the systems back to normal operation as described in the Service Manual if necessary.